

EPD-230, EPD-232

2.9" ePaper Solution Suite

NEW

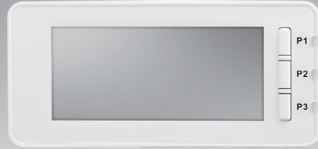

Features

- ARM Cortex-M3 Core Processor
- Supported IEEE 802.15.4 / 2.4 G Networks
- 2.9" ePaper Panel Display
- Great for Low Power Consumption
- Multiple I/O Control with Three Buttons & Three LED
- Supported Temperature Range: 0 ~ 50 °C
- High Performance Integrated System with RTOS
- Supports Over-the-Air Upgrades upgrade (OTA)
- Solution with WISE-3240 Network Coordinator & ARK ePaper Manager Server

Introduction

EPD-230 , EPD-232 supports the ultra-low power 2.4GHz RF wireless protocol integrated with 2.9" EPD in an ARM Cortex-M3 processor. The module can support hospital, pharmacy, factory, warehouse and retail applications with optimal power consumption and device management. Your applications with low data rate requirements can achieve years long battery lifetimes and thousands of device connections.

The Advantech EPD-230, EPD-232 provides multiple interfaces for application control which are highly integrated with the EPD driver and low power consumption system. EPD-230, EPD-232 can auto-join network groups with the WISE-3240 IoT Router. Data can be easily acquired and transformed into a different format to communicate with ePaper Manager Server. System integrators can focus on application development and system management.

Specifications

Computing System	MCU	TI 32-bit ARM Cortex-M3 Processor
	Memory	RAM 28KB
Display	Screen Size	79 x 36.7 mm
	Resolution	296 x 128 pixels
	Color	EPD-230 for Black & White, EPD-232 for Red/Black/White
Storage	Internal	Flash: 128 KB
	External	SPI Flash: 256 KB
Network	Standard	IEEE 802.15.4
	Frequency Band	2.4-GHz
	Channels	11~26
	Channel Separation	5MHz
	Topology	Star network
	Transmit Power	-21dBm~ +5dBm
	Receiver Sensitivity	-100dBm
	RF Data Rate	250 Kbps
	Function	End node
Antenna	On-board Antenna	
Interface		LED x3
		Function Key x3
Power	Battery	CR2450 x4 (2480mAh)
Environment	Operational Temperature	B/W color: 0 ~ 50 °C ,R/B/W color: 0 ~ 40 °C
	Non-Operational Temp.	-25 ~ 60 °C
	Operating Humidity	5 ~ 80% Relative Humidity, non-condensing
Physical Characteristics	Dimensions (W x H)	79.0 x 36.7 mm
	Weight	80g with housing and battery
Operating System		RTOS
Certification	EMC	CE/FCC/Telec/NCC

* Note:

-The channel frequency selection can be supported by further plan.

-EPD Data Report and Wakeup behavior duration can be adjusted by different scenario from RESTful API

-System bundles wireless modules; which need RED compliance

Dimensions

Unit: mm

Device

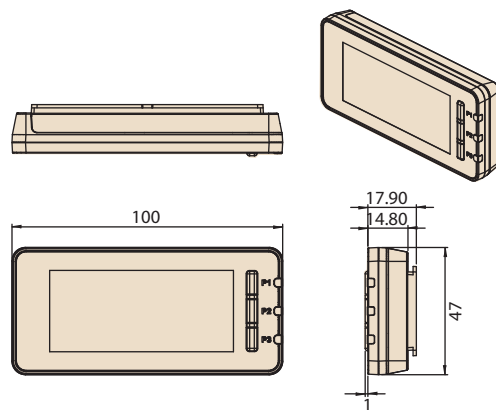

Device with Bracket

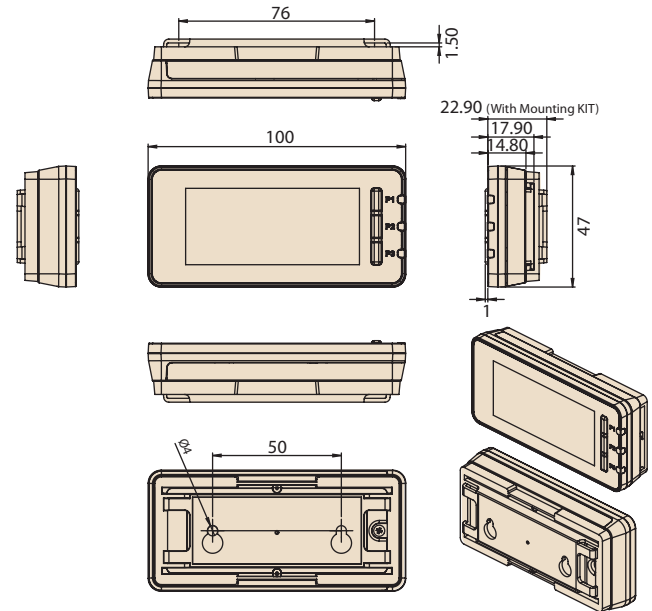

Ordering Information

Model Name	Part No.	Description
EPD-230	EPD-023B2AG-NTC02	2.9" black/white panel color ePaper device
	EPD-023B2AG-NTC12	2.9" black/white panel color ePaper device for 50pcs package
EPD-232	EPD-023R2AG-NTC02	2.9" Red/black/white panel color ePaper device
	EPD-023R2AG-NTC12	2.9" Red/black/white panel color ePaper device for 50 pcs package

Ubuntu development kit ordering information

	Part No.	Description
EPD device	EPD-023B2AG-NTC02	2.9" Wireless ePaper display device solution in 2.4G
Router	WISE-3240IOS-41A1E	Router for EU
	WISE-3240IOS-41A1J	Router for Japan
	WISE-3240IOS-41A1N	Router for NA
	WISE-3240IOS-41A1T	Router for Taiwan
	WISE-3240IOS-41A1C	Router for China
ePaper manager	ARK-1123H-EP2A2 for Entry	Ubuntu /1T HD/8G RAM and build in ePaper
	ARK-2250L-EP1A2 for Enterprise	Manager Software with 500 device licenses

Optional Accessories

Part No.	Description
1760002692-01	4 pcs CR2450 battery
1990036330T000	Wall Bracket
1990036333T000	Wall bracket Glue

Packing List

Model Name	Part No.	Description
EPD-230	EPD-023B2AG-NTC02	2.9" Black/White ePaper device with battery
EPD-232	EPD-023R2AG-NTC02	2.9" Red/Black/White ePaper device with battery

- * All E Ink Panel inspection criteria refer to E Ink CAS & Inspection standard document.
- * Note: E Ink Recommend condition for storage:
Temperature: 20 +/-10 degree C
Humidity : 60% RH+-10%RH, Non-condensing
- * Note: If panel module have been put in low temperature between 0--25 degree C for a while, we recommend to leave it between 20 to 30 degree C for 4 days before assembly.